

*"A Second Generation Synthesizer IP Block  
with a Digital Loop Filter and  $\Delta\Sigma$  Phase Detector"*

## Features

- 2 to 6 GHz operation
- $\Delta\Sigma$  Phase Detector
- Comparison Frequency 10 MHz to 40 MHz
- Input Reference Frequency up to 50 MHz
- 20-bit  $\Delta\Sigma$  Modulator gives 150 Hz step size with 40 MHz Reference Frequency
- Phase noise  $-92$  dBc/Hz at 20 kHz offset at 6 GHz with 40 MHz reference
- Spurious Response  $-80$  dBc
- Current Consumption 12 mA at 3 V
- Digitally Filtered Lock Detect
- Digital on-chip Loop Filter
- Programmable Loop Bandwidth
- Low out-of-band Noise allows wider Loop Bandwidth
- Low Spurious Response

## Applications

- WiMAX 802.16a
- WLAN 802.11a, 802.11b, 802.11g
- Multi-mode Radios

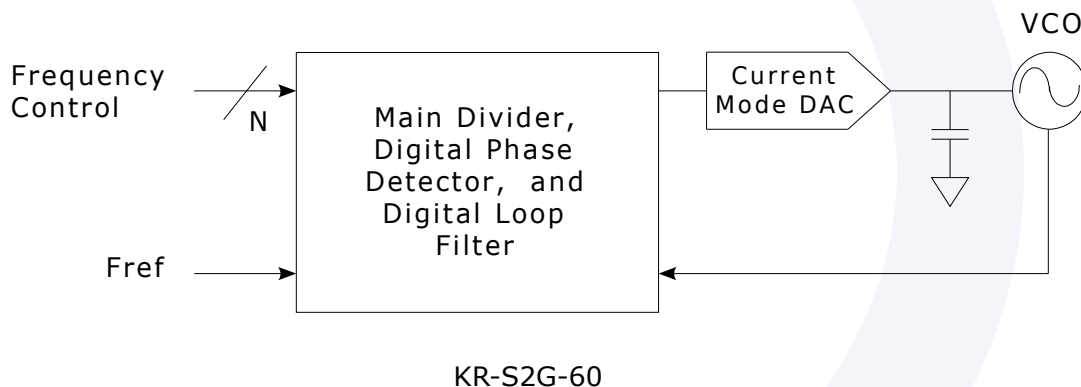

# Second Generation Synthesizer 2 – 6 GHz

## KR-S2G-60 Data Sheet

### Description

The Kaben KR-S2G-60 Second Generation Delta-Sigma ( $\Delta\Sigma$ ) Fractional-N frequency synthesizer cell provides fine step size, low phase-noise, low spurious levels, fast switching speed, and low out-of-band noise. This synthesizer is a key building block in designing multi-standard SoCs.

When integrating the Second Generation  $\Delta\Sigma$  Fractional-N synthesizer core into your SoC, our engineers support your design for system-level integration and verification, fabrication, and maximum re-use.

The Kaben KR-S2G-60 has a maximum output frequency of 6 GHz while maintaining step sizes of 150 Hz using the 20-bit  $\Delta\Sigma$  modulator making it ideal for all platforms.

The KR-S2G-60 employs a  $\Delta\Sigma$  Phase Detector that enables advanced digital filtering techniques that significantly reduce out-of-band quantization noise. As there is less quantization noise to suppress, the loop filter can be made wider thus improving switching speed and providing higher VCO noise suppression.

The digital on-chip Loop Filter eliminates pins and component count. Having the Loop Filter on-chip means that the synthesizer does not need to be on the edge of the chip which is advantageous in pad limited SoCs.

Further, the digital loop filter bandwidth can be programmed on the fly enabling multi-standard, multi-band, and multi-VCO architectures.

The synthesizer cell uses a high internal reference frequency of up to 40 MHz to achieve a close-in phase noise of -92 dBc/Hz from a 6 GHz synthesizer. Spurious response of -80 dBc makes this product an ideal selection for applications where interference from adjacent or alternate channels is a significant issue.

### Support

Support can be provided for all phases of the life cycle of your SoC. For system design, we provide a kit that includes high-level models in Matlab/Simulink. System-level models offer various modes of abstraction for flexibility in simulation speed vs. accuracy. Included is a loop-filter design kit for tailoring the trade-off between VCO noise and synthesizer phase noise. All high-level models are based on measured data.

At the circuit design level, Kaben's Release Kit contains GDSII files, Verilog files, and Cadence™ design libraries containing test benches, schematics, symbols, and cell layouts. For production test, the cell has a built-in signature analysis block.

### Electrical Characteristics

Parameter	Conditions	Min	Typical	Max	Units
Analog Supply Voltage		2.7	3.0	3.3	V
Digital Supply Voltage		0.9	1.0	1.1	V
Total Supply Current	VCC = 3 V, Temp = 25 °C, FREF = 40 MHz, fVCO = 6 GHz		12		mA
RF Input Operating Frequency		2		6	GHz
Comparison Frequency		10		40	MHz
Reference Oscillator Input Frequency	Reference Oscillator is off-chip	10		50	MHz
RF Input Sensitivity	Peak-to-peak single ended	150		300	mV
Synthesizer contribution to close-in Phase Noise	FREF = MHz RF signal = GHz Offset = kHz		-92		dBc/Hz
Spurious Levels	When carrier is within one Loop Bandwidth of an Integer multiple of the Reference Frequency			-60	dBc
	When carrier is more than 10 Loop Bandwidths away from an Integer multiple of the Reference Frequency		-80		
Integer Divider Range		100		600	
Frequency Resolution		$\frac{2 \cdot F_{REF}}{2^{20}}$			Hz
Operating Temperature (Junction)		-40		+85	°C

